

Taylor Wimpey Uk  
Site HSE Manual

Section 11  
Timber Frame

Document Owner

Craig Schwarze	Head Of HSE
----------------	-------------

## Table of contents

11.1 TIMBER FRAME DOCUMENTS.....	3
11.2 SITE MANAGEMENT ARRANGEMENTS .....	3
11.3.1 TIMBER FRAME ERECTION SUPERVISOR .....	3
11.3.2 OPERATIVES.....	4
11.4 MONITORING and INSPECTION .....	4
11.5 TIMBER FRAME FIRE CONTROLS.....	4
11.5.1 FIRE POINTS.....	4
11.5.2 EMERGENCY ESCAPE ROUTES.....	5
11.5.3 TIMBER FRAME (FIRE SAFETY) SITE CHECKLIST .....	5
11.5.4 SITE SECURITY .....	6
11.6 RISK ASSESSMENTS and SAFETY METHOD STATEMENTS.....	6
11.7 TIMBER FRAME PRE-START MEETING .....	6
11.8 TRAFFIC MANAGEMENT .....	7
11.8.1 OFF LOADING / STORAGE.....	7
11.8.2 POSITIONING OF MOBILE CRANES.....	8
11.8.3 TIMBER FRAME DELIVERIES .....	8
11.9 SITE MANAGEMENT KEY CONSIDERATIONS.....	8
11.9.1 LIFTING OPERATIONS PLAN.....	8
11.9.2 SCAFFOLD DESIGN AND SCAFFOLD ARRANGEMENTS.....	9
11.9.3 STABILITY OF PANELS / SUPPORT.....	9
11.9.4 STAIRWELL PROTECTION / ACCESS .....	9
11.9.5 KNOCKOUT ACCESS PANEL(S).....	9
11.9.6 FALL PREVENTION / PROTECTION.....	10
11.9.7 ROOF CONSTRUCTION / STA LADDERS .....	10
11.9.8 PLASTERBOARD SLOTS .....	11
11.9.9 WASTE.....	11
11.9.10 PLOT HANDOVER .....	11

## 11.1 TIMBER FRAME DOCUMENTS

For ease of reference and in addition to the Construction Phase Plan, a separate Timber Frame Documents Folder is made available, containing the following information:

- Timber frame development selection checklist
- Off Site Fire Risk Assessment
- Timber Frame Fire Safety Checklist
- Timber Frame Installation Key Stages
- Scaffold Designs
- Timber Frame Pre-Start Meeting Minutes
- Timber Frame Construction T06 Timber Frame Contractor
- Fire Safety Plan & Checklist (**Folder 2, F2.12**)
- Timber Frame Fire Safety Checklist (**Folder4, TF4.10**)
- Timber Frame Pre-Plot Commencement Safety Checklist (**Folder 4, TF4.11**)
- STA 16 Steps to Fire Safety
- Radiant Heat Plan

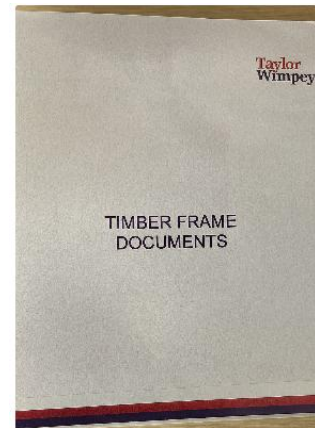

F2.12

**F2.12 Fire Safety Plan and Checklist (Traditional Build)**

Fire Safety plan and Checklist

TF4.10

**TF4.10 Timber Frame Fire Safety Plan and Checklist**

Timber Frame Fire Safety Plan and Checklist

TF4.11

**TF4.11 Timber Frame Pre-Plot Commencement Safety...**

Timber Frame Pre-Plot Commencement Safety Checklist

## 11.2 SITE MANAGEMENT ARRANGEMENTS

In addition to the Taylor Wimpey UK Core Training ([see Section 1.2.4](#)) any Site Manager/Assistant Site Manager left in charge of a site where Timber Frame erection is being undertaken, will need to ensure the appropriate additional training has been carried out for the management of Timber Frame developments. This includes the TW ‘Managing Timber Frame / Fire Safety’ Workshop.

### 11.3.1 TIMBER FRAME ERECTION SUPERVISOR

No Timber Frame Construction can be undertaken without the Nominated Timber Frame Erection Supervisor on site. The Timber Frame Erection Supervisor must:

Timber Frame – Direct Trade	Timber Frame – Contractor
TW trained and completing / completed STA Workbook(s) (STA Erector Knowledge, Practical and Health & Safety Skills Workbook)	Hold a current SMSTS or SSSTS qualification
Be fully familiar with the agreed safe system of work and controls to be adopted on site.	Be fully familiar with the agreed safe system of work and controls to be adopted on site.
NOTE: If the suitably trained operative leaves, or does not attend site, the Timber Frame erection must be suspended until a trained and nominated substitute operative is in place.	NOTE: If the Supervisor leaves, or does not attend site, the Timber Frame erection must be suspended until a trained and Timber Frame Supplier nominated substitute Supervisor is in place.

### 11.3.2 OPERATIVES

The Contractors must provide details of their Operatives' Safety Critical Training, e.g., Timber Frame Erection, Slinger/ Signaller, Nail Gun, etc. This can be provided by way of copies of:

- The individual's training certificates; and/or
- The employers H&S training matrix.

### 11.4 MONITORING and INSPECTION

The Site Management Team with the support of their Timber Frame Erection Supervisor, Production Manager and Site HSE Advisor must carry out regular monitoring of work underway, particularly where high-risk work is being carried out e.g., Lifting operations, work at height etc.

The Site Manager is responsible for:

- The supervision of the timber frame operations; and
- Carrying out and recording the statutory inspections including:
- Work at Height e.g., Proprietary deck inspections / podium steps
- Work Equipment e.g., nail guns

Where an Timber Frame Erection Company is being used (Supply and Erect then these duties must be undertaken by the Timber Frame Erection Supervisor. At this time the Site Manager is responsible for;

- Carrying out regular monitoring checks on the works and check that the Timber Frame Erection Supervisor is carrying out the safety critical checks

Additionally when a Timber Frame Erection Company are used then Contractors HSE Advisor must:

- Complete a Monthly Site HSE Inspection / Audit (as a minimum)
- Provide the TW Site Manager and Timber Frame Erection Supervisor with a copy of their report

The report must clearly identify:

- Any concerns / shortfalls with immediate actions taken and required
- Include forthcoming / planned works and note controls agreed

### 11.5 TIMBER FRAME FIRE CONTROLS

There are 2 levels of fire precautions depending on the size and complexity of the Timber Frame structures being built:

- **LEVEL 2** for detached, semi-detached and terraced housing, and
- **LEVEL 3** for higher risk situations e.g., multi storey buildings and apartment blocks that may have more complex escape routes and increased fire loadings.

Some sites may have both Level 2 and Level 3 fire precautions in place, Level 2 around the site where timber frame houses are being built and Level 3 within any timber frame apartment buildings or terraces of 4 or more houses under construction.

The Site Management Team must contact the local Fire Brigade and discuss the potential fire risks during construction. Prior to commencing work on any Timber Frame development, information must be provided via the Technical Team to the local fire services including development layouts identifying the location of live fire hydrants.

#### 11.5.1 FIRE POINTS

Within the timber frame build area the fire alarms and extinguishers are contained within the designed 'fire points' that can also include a fire plan where necessary, 'Type 2' fire points are required for timber frame

**Type 2: Fire Point Consisting of:**

- Interlinked Push button fire alarm
- 9L water extinguisher
- 6kg powder extinguisher
- Instructions of what to do in an emergency
- Location plan (if in an apartment building)
- Weatherproof as can be located outside or exposed to the elements



Where necessary, mobile fire point units fitted with appropriate fire extinguishers can be used e.g., small work in remote areas, etc.

**11.5.2 EMERGENCY ESCAPE ROUTES**

In the event of a fire within a timber frame build area the area must be evacuated quickly and efficiently.

Level 2 escape routes from standard detached and semi-detached plots are via:

- the scaffold staircase,
- or via the mid floor access hatch by accessing the plot from the ‘knock out’ panel.

**NOTE: this panel must not be fitted until the internal staircase are installed.**

Level 3 escape routes from all apartment blocks requires two or more means of escape being provided from each floor, with the escape provided via:

- Out on to scaffold and down the scaffold staircase(s), also
- Via the internal permanent stairs once installed

Where escape routes exceed 25m, then those routes must provide 30 minutes of fire protection until the timber frame structure is ‘covered in’ i.e., external masonry skin and internally boarded (floor, walls and ceilings).

Internal escape routes must also have emergency lighting and appropriate emergency directional signage to aid any escape

Where scaffolds require a secondary access / egress these are constructed with the same principals as the initial access and egress, i.e., Proprietary Staircases, under no circumstances can ladder towers be implemented as the emergency route.

**11.5.3 TIMBER FRAME (FIRE SAFETY) SITE CHECKLIST**

The **Timber Frame (Fire Safety) Site Checklist (Construction HSE Plan – Folder 2, F2.27)**, assists the Site Manager to check that critical fire protection systems and controls are in place.

**Responsibility:**

- Site Manager/Assistant Site Manager

**When:**

- Prior to Timber Frame Erection and reviewed and completed monthly

**Purpose:**

- Ensure that the key controls are in place to manage fire safety on Timber Frame plots.
- Ensure that the required alarms, extinguishers, etc. are available.
- Identify if additional timber frame precautions required.

	Muster Points
	Fire Points (Alarms and Extinguishers)
	Location of Fire hydrants
	Compound Location - these must be at least 20 Meters away from any Timber Frame
	Car Parking - these must be at least 20 Meters away from any Timber Frame
	Fuel Storage Area - these must be at least 20 Meters away from any Timber Frame
	Any fire mitigation – increase in fire resistant timber e.g cat C timber
	Waste - Location of Skips etc. - these must be at least 20 Meters away from any Timber Frame
	Means of Escape

The Site Manager, using the checklist must address the following:

- Fire Safety Plan
- Timber frame handover
- Induction
- Hot works
- Housekeeping
- Storage
- Smoking
- Plant and equipment
- Fire detection, alarm and firefighting
- Means of escape
- Security
- Test and inspection

The fire plan and layout drawings for Timber Frame erection must be firstly drawn up in consultation with your Regional / Site HSE Advisor and HSE Co-ordinator prior to Timber Frame Erection commencing. It must then be continuously reviewed throughout the build stages, especially after any significant changes (e.g., change to route of build). If there is any significant change then consultation is required with your RHSEA.

#### **11.5.4 SITE SECURITY**

Increased security measures must be considered during the “high risk” phase of timber-frame construction, with reference made to the Timber Frame Fire Risk Assessment ‘off-site’ and ‘on-site’

#### **11.6 RISK ASSESSMENTS and SAFETY METHOD STATEMENTS**

Timber Frame contractors must provide their risk assessments and safety method statements for review prior to the Timber Frame Pre-start Meeting.

The Site Management Team are to familiarise themselves with the risk assessments and confirm with the Timber Frame Erection Supervisor(s) they have briefed their operatives on the agreed safe system of work prior to commencing the works.

#### **11.7 TIMBER FRAME PRE-START MEETING**

Before Timber Frame activities commence on site, the Site Management team and Timber Frame Contractor and any other Timber Frame trade appointed to work within the designated areas must attend an On-site related Pre-Start Meeting.

The Production / Site Management Team organise this meeting 6 to 8 weeks prior to the delivery of the first Timber Frame kit.

#### **Pre-start Meeting Agenda**

Attendees: For TW – Production Director / Manager, Site Manager/ Assistance Site Manager and Regional/Site HSE Advisor

For CONTRACTOR – Timber Frame Contracts Manager, Timber Frame Erection Supervisor, Groundworks Supervisor, and Scaffold Supervisor

##### **1. Review of roles and responsibilities**

- Site Management (TW Contractors) organisation/co-ordination/supervision.

##### **2. General Arrangements**

- Risk Assessment/Safety Method Statement review.
- Plant and Equipment.
- Training records
- Fire and emergency arrangements (Timber frame fire precautions)
- Security and public protection.

##### **3. Traffic Management Arrangements and Deliveries**

- Site / Timber Frame Area Traffic Management Plan
- Traffic Management arrangements for all delivery vehicles (Delivery restrictions / specific considerations).

- Material storage arrangements (Just in time delivery or lay down areas)

#### **4. Timber frame installations**

- Programme/sequence of works
- Work at height arrangements i.e. proprietary decking system
- Fixing Schedule and bracing schedule

#### **5. Lifting Operations**

- Lifting Operations Constraints (Overhead restrictions or Ground conditions)
- Crane positions/locations identified
- Exclusion Zones

#### **6. Groundworks**

- Haul roads or crane base requirements
- Service Work
- Programme/sequence of works

#### **7. Scaffold**

- Scaffold designs confirmed and available
- Location of loading bays and proprietary stair access towers
- Work at height/Fall prevention requirements

#### **8. Other**

- Timber Frame Pre-Plot Commencement Checklist
- Handover Arrangements
- Waste Segregation and Disposal

### **11.8 TRAFFIC MANAGEMENT**

Prior to the commencement of each Timber Frame plot, the Site Management Team must plan and prepare a Traffic Management system to enable people, plant and vehicles to safely operate around the plot. Consideration must be given to deliveries and temporary road closures and where exclusion zones need to be established around cranes etc. For further details regarding Traffic Management Plans (see **Section 2.2.3**).

The following must be clearly identified:

- Established and maintained pedestrian routes including suitable signage
- Delivery holding areas
- Unloading areas for delivery vehicles; and
- Material lay-down areas

It is important to plan all aspects of traffic management with the Timber Frame Erection Supervisor, so there is a coordinated approach. Consideration needs to be given to the agreed crane position so delivery and any lay-down areas can be established and maintained with minimal impact on the surrounding traffic management systems.

#### **11.8.1 OFF LOADING / STORAGE**

Timber Frame Suppliers must load their delivery vehicles in such a way as to avoid work at height, with either pre-slung loads, accessible from the ground, or draw cords between each panel pack so webbed slings can be attached and pulled through. If such measures are not in place, the delivery must not be accepted.

All other materials related to Timber Frame erection must be delivered palletised or in stillages to prevent movement of the load e.g., loose timber packs. Due to the nature of these ancillary packs, an assessment is made to identify if driver needs to access the bed or back of the vehicle to carry out any part of the unloading / loading activity. **If it is identified that the unloading involves the need to access the lorry bed controls to manage the risk must be in place such as edge protection, restraint straps etc. If no controls – No access is permitted to the bed of the vehicle.**

Where materials are craned into position directly from the delivery vehicle, Consideration must be given to the impact on traffic management and access/egress with alternative arrangements put in place before the lifting activity commences.

Timber panels and floor cassettes are craned directly into position from the delivery vehicle. However, there may be occasions where this is not possible, and laydown areas are required. This could be on an adjacent plot slab or other suitable area as close to the plot as possible to avoid the need to transport materials on site.

Prior to the off-loading, the designated laydown area must be clearly identified and kept clear. Segregated walkways provided to enable the slinger/signaller to work safely without any conflict with other mobile plant on site traffic.

### 11.8.2 POSITIONING OF MOBILE CRANES

The positioning of mobile cranes must take into consideration:

- Existing services
- Ground conditions
- Proximity to excavations; and
- Other potential hazards.

Prior to any crane arriving on site, an assessment of the ground conditions must have been carried out and where necessary, compaction testing of the ground undertaken to ensure that any 'made up' ground is suitable to withstand the imposed loads.

The Timber Frame Erection Supervisor **MUST NOT** re-site mobile cranes or deviate from the agreed lifting plan unless formally reviewed and approved by the mobile crane Appointed Person.

Immediately prior to commencing lifting operations, the Slinger/ Signallers must ensure the following items have been considered:

- Exclusion zone is in place with physical barriers to segregate pedestrians and site operatives.
- Slings checked for any damage, knots, wear & tear and are fit for purpose and are at the correct angle.
- Load is unobstructed and ready to be raised.
- Safety catches are in place on hooks and are free from damage or defects.
- Site personnel are clear of the load to be lifted and sufficient resource is in place to observe the load as it travels to the landing point.
- Slinger/ signaller is in place to land the load.
- Landing point is clear from site personnel and load is ready to be received.
- Weather conditions have been assessed and deemed suitable to carry out the lift.
- Communication method has been agreed with the crane operator.

Only when all of the above criteria have been reviewed, can the Slinger / Signaller proceed with the lifting operation.

### 11.8.3 TIMBER FRAME DELIVERIES

All timber frame suppliers to TW sites must have been given instructions via their Commercial Department on safe working practices for subsequent distribution to their drivers (see **Section 8.7.1**).

These instructions include:

- Use of suitable PPE
- Reporting to the site management team
- Work at height controls (where access at height necessary)
- Safe off-loading (including reversing, parking, following traffic routes etc; and
- The specific offloading/storage controls below

### 11.9 SITE MANAGEMENT KEY CONSIDERATIONS

Prior to the commencement of any Timber Frame erection on site, the Site Manager must review and plan several key elements to enable the Timber Frame erection to be carried out safely.

#### 11.9.1 LIFTING OPERATIONS PLAN

Prior to any lifting operation on timber frame buildings a trained Appointed Person must visit site to prepare a Lift Operations Plan, including:

- an assessment of the ground including underground and overhead hazards
- the selection of crane and lifting gear
- slinging and signalling arrangements; and
- supervision of the lift
- Details of the lifting plan must be passed on to the TW Site Manager and Timber Frame Erection Supervisor for review prior to the lift taking place.

Only once the Lifting Operations Plan has been suitably developed, the operatives brief on the safe system of work and agreed by the Timber Frame Supervisor and the TW Site Manager, can the timber frame activities commence.

As part of the overall assessment, it must identify where materials are to be laid down/ stored / secured and protected.

### **11.9.2 SCAFFOLD DESIGN AND SCAFFOLD ARRANGEMENTS**

Due to the nature of Timber Frame, all scaffolds involved must be designed as there is a period when the scaffold is 'free standing'.

The Technical Team in conjunction with Production team must identify where timber frame scaffolds are required and confirm with the appointed Scaffold Contractor that suitable scaffold designs are available for each of the identified timber frame plots.

Access to all timber frame scaffolds is via proprietary Staircases (see **Section 5.1.8**)

As access is required to the upper lifts of the scaffold before the timber frame erection starts, all Timber Framed scaffolds must have a double internal handrail in place to prevent falls from heights.

The handrails must remain in place until the fall potential is eliminated i.e., proprietary decking system or floor cassettes installed.

### **11.9.3 STABILITY OF PANELS / SUPPORT**

- Panels are erected starting at an external corner at 90 degrees (see Image).
- Temporary props are fitted at both ends of the panel 600mm in from each end at a 45 degrees angle
- The return panel is then installed and fully nailed at corner junction and at base
- A single prop is installed 600mm in from end of panel.
- Bracing must then be positioned and fixed using a 95mm x 22mm timber brace fixed to the face of the panel at an angle of 45 degrees ensuring that the external panel is in a plumb position.
- The panels are now secure and plumb, and the same method can be used to erect the remainder of the panels.

### **11.9.4 STAIRWELL PROTECTION / ACCESS**

- When fitting stairs, there are critical steps in the installation process which must be taken before the stair may be used, even for temporary access.

These critical steps are:

- Install 'Airtec' edge protection on mid-floor
- Remove sacrificial floor
- Install stairs - for Stair Installation Guidance (**LINK**)
- Install 'Airtec' handrails to side of stairs

### **11.9.5 KNOCKOUT ACCESS PANEL(S)**

To assist in the installation and dismantling of internal fall protection a 'Knock-out Panel' is left out to provide access from the scaffold and reduce manual handling issues.

The access point also allows an additional escape route as part of our Fire Safety measures

### 11.9.6 FALL PREVENTION / PROTECTION

Prior to commencing any work to the roof trusses, a proprietary deck must be in place (see **Section 6.2**). When installing Proprietary decking the following controls must be implemented:

- Copy of the manufacturer’s installation instructions available on site
- Operatives erecting the specific system trained and qualified to install and check the type of deck being installed
- Operatives erecting the system provide a ‘handover certificate’
- Site Management team have received familiarisation training on the system; and
- The system inspected by the Timber Frame Erection Supervisor at handover before every shift (need not be recorded) and then every 7 days or after adverse weather
- The Site Manager must also carry out and record regular inspections

Alternatively, the roof structure can be built a ground-level (space permitting) and then craned into position on the timber frame plot

This method minimises work at height as most of the work is carried out at ground level, with low level access equipment used to access the upper parts of the roof.

Prior to the roof structure being lifted into position, STS Trellis Mats (or similar) must be installed across the truss cords to provide fall protection for all subsequent work once the roof structure is in its permanent position.

**NOTE:** The fall protection system, either proprietary decking or trellis mat must remain in place until the roof is at least felted, battens and tile/slate installation (see **Section 6.8.2**)

### 11.9.7 ROOF CONSTRUCTION / STA LADDERS

Access for the roof truss installation is normally via the installed perimeter scaffold. Trusses must be temporarily braced (see **Section 6.9**) as they are lifted into place and again as they are ‘spread & spaced’ to the required position along the wall plate.

Safe access to complete high-level apex bracing or complex bracing, e.g., steep pitched roofs and attic trusses etc. is provided with the use of the Safe Truss Access Ladder (STA):

Safe Truss Access Ladder (STA) and Access Boards:

- provides a safe means of access across truss chords and to higher levels of the truss where apex bracing needs to be fixed.
- the upper spreader bar spans the gap across the trusses at high level; and
- the welded spreader bar at the base of the ladder sits securely into the “V” point of the truss.

A Safe Truss Access Ladder [STA] set, including access boards, must be held on all sites carrying out roof truss installations.

Further guidance on the STA Ladder System can be found in [Section 6.8.7](#)



### 11.9.8 PLASTERBOARD SLOTS

The use of plasterboard slots must be considered on all plots; however, they must be fitted in all plots with a kite winder or other staircase where the layout makes it difficult to manually handle the boards. (see Section 7.1.10)

Where a slot has been installed, the contractor(s) must instruct their employees that the slot must be closed over when not in use.

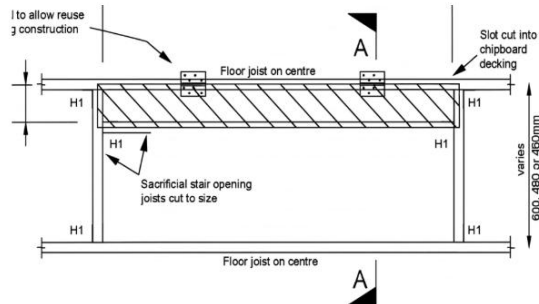
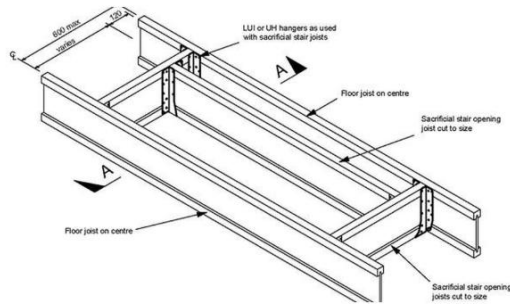

### 11.9.9 WASTE

The Timber Frame supplier scope of work includes the removal of all waste, with pre-arranged collection, all large timber waste from the installation for re-use and/or recycle e.g., sacrificial floor area.

Rooms must not be used as waste storage areas. All wood/waste/cuttings to be removed daily.

**NOTE:** Due to the volume of combustible materials involved and the increased fire risk, waste and waste skips must not be stored near the Timber Frame buildings during construction.  
No burning of any material on site.

### 11.9.10 PLOT HANDOVER

The Timber Frame Erection Supervisor, following the complete installation of the timber frame kit, confirms with the site manager using the Timber Frame Handover Form (see **Timber Frame Production Manual**) to demonstrate that the installation has been erected as per the design layout and detail and is ready for the next build stage and other contractors.